

MSL1002

LED Motion Security Floodlight

Operating at 100-240 volts, this Adjustable 2-Head LED Security Light with Motion Sensor and Photocell offers exceptional performance while reducing energy and maintenance costs on lighting applications.

Elitco Lighting

by
Elegant



Performance

- Photocell allows for automatic on and off functions between dusk and dawn.
- Delivers 270-degree coverage and up to 60-ft.
- Suitable for wet location use.
- It features LED technology with a 30,000 hours LED life.
- Ideal for both residential and commercial areas such as yards, driveways, patios, loading areas and warehouses.

Construction

- Die-cast Aluminum for excellent heat dissipation
- IP65 Waterproof

Installation

- Surface Mount With J-box
- Size: L11.18"(284mm)*H9.57"(243mm)*W6.89"(175mm)

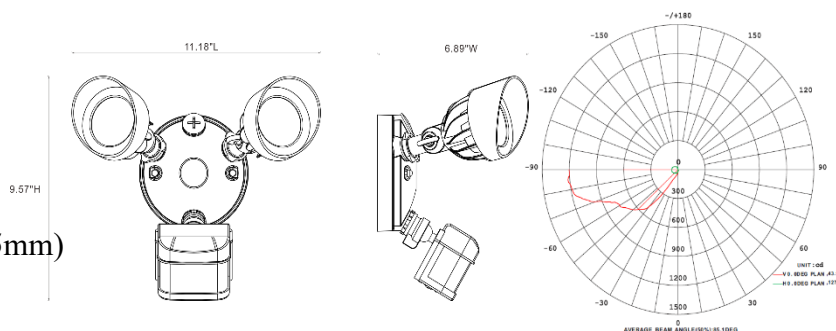

Specifications

Category	Motion Security Light	Individual Box Length (INCH)	10.80
Bulb Shape	Round	Individual Box Width (INCH)	7.28
Bulb Base Type	Integrated LED	Individual Box Height (INCH)	5.90
Bulb Base Finish	N/A	Individual Box Weight per Unit (LBS)	2.87
Color Temperature	5000K		
Beam Angle	270°		
Finish	Dark Bronze		
CRI	80		
Average Life (Hours)	30000		
Estimated Yearly Energy Cost (11 ¢ /Kwh)	2.89	Lamp Type	LED
Life Based On 3Hrs/Day (Years)	27.40	Dry/Wet/Damp	Wet
Product Length (Inch)	11.18	Energy Star	NO
Product Width (Inch)	6.89	Power Factor	0.9
Product Height (Inch)	9.57	Current	0.24A
Product Extension (Inch)	N/A	Lumen/Watt	75
Product Weight Per Unit (Lbs)	2.15	Warranty (Year)	2
Dimmable	NO	DLC (Yes/No)	NO
Watts	24W	Input Voltage	100-240V
Watt Equivalent	150W	Housing Material	Aluminum
Lumens	1800	Lens	Tempered Glass
Certification (UL/ETL/FCC)	UL	Led Type	Hongli