

DISPLACEMENT

MDK

16-48" (406-1219mm)

The rugged MDK pig was specifically developed for use during the testing stage of mainline pipeline construction projects.

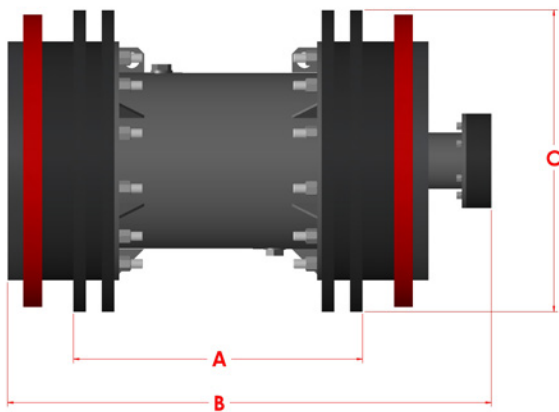

Size	A	B	C	Weight	Part #
16"	15.000	28.250	15.875	161	70-7776-16
20"	19.250	34.750	20.000	264	70-7776-20
24"	23.750	38.500	24.000	372	70-7776-24
30"	29.750	48.875	30.250	632	70-7776-30
36"	35.250	52.500	36.500	816	70-7776-36
42"	41.250	65.500	42.125	1208	70-7776-42
48"	46.500	72.750	48.875	1500	70-7776-48

Features & Benefits:

- The MDK pig features an inner and outer mandrel. Because the inner mandrel withstands the punishing battering inflicted during the construction process, and the exterior disc carrying the outer mandrel remains untouched, the MDK dual mandrel is preferred by mainline contractors, every pig is equipped with a durable guide disc at each end. These discs center the sealing discs in the line, which allows the four sealing discs in the center to form a quadruple seal during displacement.
- Standard bumper noses cushion the pig and help to protect in-line auxiliary equipment, preventing damage.
- To maximize durability, all discs are made from Reliathane, Apache's special blend of wear-resistant polyurethane.
- Every Apache MDK 16"- 48" pig is manufactured with by-pass ports. These ports feature threaded plugs that can be removed, should by-pass be required.

Designed to negotiate 1.5D bends, the MDK pig moves reliably through piping systems.

Options Available:

- Circular flange brushes or block brushes in the following types and trim materials (not available for testing):
 1. Trim types – flat wire or pencil.
 2. Trim material – carbon steel, stainless steel, plastic, or tin-coated.
- Transmitter housing to accommodate electronic tracking equipment.
- CARVER discs.
- Aluminum gauge plates in slotted or standard styles.
- Magnets can be used to either collect ferrous and other construction debris, or they can be used to provide a change in magnetic field required by non-intrusive pig signaler detection devices.

1575 - 90 Ave Edmonton, AB Canada T6P 0E2

Ph: 780.416.4850 | Fax: 780.416.4829 | apachepipe.com | Email: sales@apachepipe.com

2-45

world class world wide